

GENERAL DESCRIPTION / APPLICATIONS

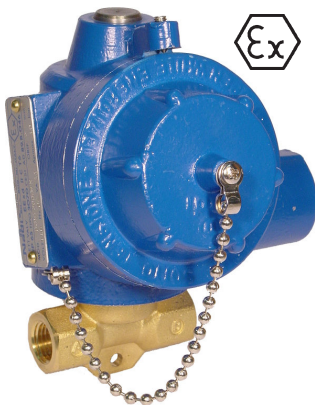

Two way direct acting solenoid valve with spring return.

Suitable for gaseous and liquid media compatible with the (body/seals) material used, vacuum.

Forged brass, nickel-plated brass or stainless steel body.

Stainless steel internal parts.

Stainless steel springs.

360° degrees orientable solenoid.

Mountable in any position.

DIMENSIONS (in mm)

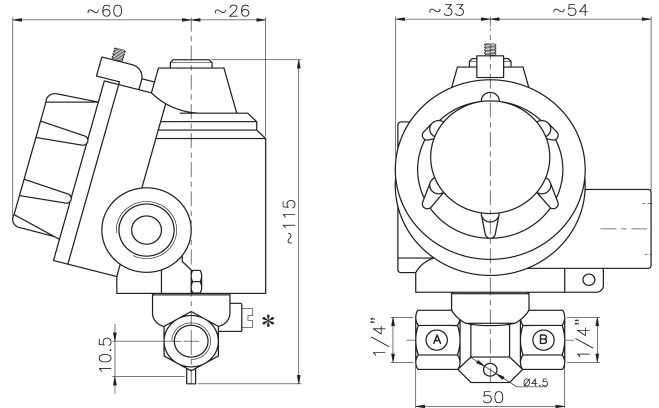

* Optional Manual Operator

ELECTRICAL SPECIFICATIONS

Light alloy explosion-proof "Ex-d" (EN60079-1) solenoid housing. Electrical and mechanical parts certified according to 2014/34/UE ("ATEX") directive, suitable to control the flow of inert and/or flammable gases or liquids. Internal and external anti-twist ground connecting screws. Inside terminal board suitable for cable up to 2,5 mm².

cable entry threaded:	1/2" NPT (standard) ISO M20x1.5 (available upon request)
protection class:	IP-67
Ex protection class:	Ex-d II 1G/2GDc (IIB o IIC)
Temperature class:	T6 or T5 (t.amb -20 ÷ +40 °C) T5 or T4 (t.amb -20 ÷ +60 °C) upon request. T5 or T4 (t.amb -60 ÷ +60 °C) upon request
Coil insulation class:	F (155°C) - H (180°C) upon request.
Winding wire class:	H (180°C).
Duty:	Continuous (S.I.) 100% ED
Power consumption ₍₂₎ :	Alternate current 11VA (inrush 28VA). Direct current 11W.
Tolleranza tensione:	± 10% (standard) others available upon request
Voltage tolerance:	± 10%
Insulation:	>1000 MOhm
Dielectrical Strength:	>2000 V/1'
Standard voltages	12, 24, 48, 110, 115, 125, 220, 240 Volt
DC= ₍₄₎ o AC~(50/60Hz):	other voltages available upon request.

OPERATION



L03 - Normally closed.

In: A
Out: B
Coil de-energized: A and B closed.
Coil energized: from a A to B.

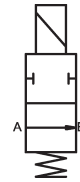

L08 - Normally open.

In: A
Out: B
Coil de-energized: from A to B.
Coil energized: A and B closed.

SPECIFICATIONS AND AVAILABLE OPTIONS

MODEL	ORIFICE DIAMETER mm	BODY RATING	PRESSURES IN BAR ⁽³⁾				Flow factor kv (liters/min.')	WEIGHT Kg.
			MIN./MAX. OPERATING DIFFERENTIAL PRESSURE					
Replace with L08 for N.O. model			MIN.	MAX. NORM. CLOSED AC~	DC=	MAX. NORM. OPEN AC~	DC=	
L 0 3	a 0 8		0	60	60	40	40	0,2
L 0 3	1 8		0	25	20	14	14	1,2
L 0 3	2 5		0	20	18	5	5	1,6
L 0 3	3 2		0	14	10	3	3	1,8

suffix (options available upon request): ⁽¹⁾ "LT" (low t.amb. certificate), ⁽²⁾ "LC" (low consumption), ⁽³⁾ "AP" (High pressure version)- ⁽⁴⁾ "V" spike suppressor.

a	b	c	d	e
Body material	Port size	Seals material	Protection class	Optional feature
T Brass. I Stainless steel.	C 1/4" GAS D 1/4" NPT	0 Buna N 1 FPM 3 PTFE 6 EPDM 8 FFPM	B Ex-d IIB C Ex-d IIC	X Stable manual operator.