

GENERAL DESCRIPTION / APPLICATIONS / DIMENSIONS

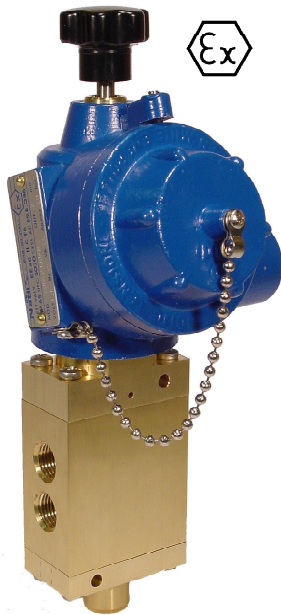

- Five way manual-reset solenoid valve.
- Suitable for gaseous media.
- Model for liquid media available upon request.
- Stainless steel internal parts. Stainless steel spring.
- Stainless steel internal parts.
- Stainless steel springs.
- 360° degrees orientable solenoid.
- Mountable in any position.

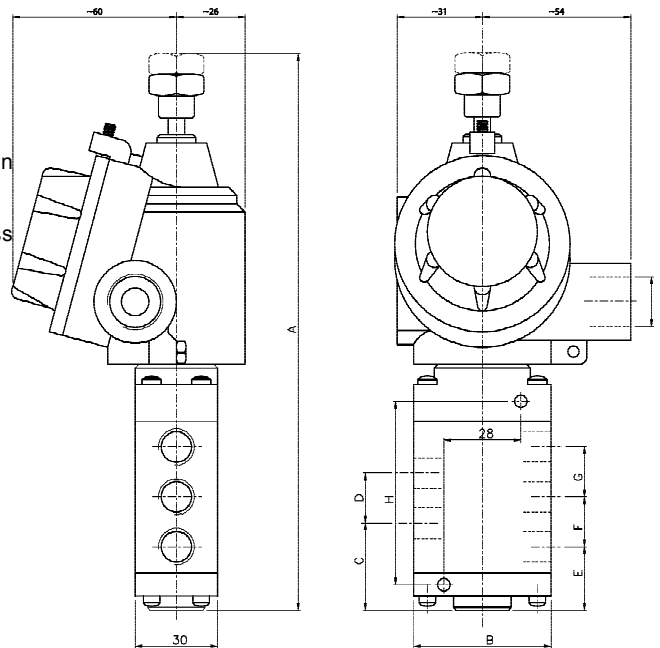

ELECTRICAL INFORMATIONS

Light alloy explosion-proof "Ex-d" (EN60079-1) solenoid housing. Electrical and mechanical parts certified according to 2014/34/UE ("ATEX") directive, suitable to control the flow of inert and/or flammable gases or liquids. Internal and external anti-twist ground connecting screws. Inside terminal board suitable for cable up to 2,5 mm².

- cable entry threaded: 1/2" Gk UNI-6125 (standard)
1/2" NPT, ISO M20x1.5 (available upon request)
- protection class: IP-67
- Ex protection class: Ex-d II 1G/2GDc (IIB o IIC)
- Temperature class: T6/T5 (t.amb -20 ÷ +40 °C)
T5/T4 (t.amb -20 ÷ +60 °C) upon request.
T5/T4 (t.amb -60 ÷ +60 °C) upon request⁽¹⁾,
F (155°C) - H (180°C) upon request.
- Coil insulation class: F (155°C) - H (180°C) upon request.
- Winding wire class: H (180°C).
- Duty: Continuous (S.I.) 100% ED
- Power consumption: Alternate current 11VA (inrush 28VA).
Direct current 11W.
- Tolleranza tensione: ± 10% (standard) others available upon request
- Voltage tolerance: ± 10%
- Insulation: >1000 MOhm
- Dielectrical Strength: >2000 V/1"
- Standard voltages 12, 24, 48, 110, 115, 125, 220, 240 Volt
- DC= (2) o AC~(50/60Hz): other voltages available upon request.

* Alternate current operation (Vac~) is performed using a direct current coil fitted with an internal rectifier (Nadi coil type B6/R)

OPERATION

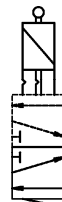

"Rest"



"Work"

Five way manual reset solenoid valves are normally used to realize safety pilot devices for single-acting actuators.

Manual reset solenoid valves can only change from "Reset" to "Work" condition operating the latching device manually.

"E" type operation

Spool of the valve is manually latched to the "Work" condition with the coil de-energized. Energizing the coil the spool will be unlatched and the valve will come back to the "Rest" position.

"D" type operation

Spool of the valve is manually latched to the "Work" condition with the coil energized. De-energizing the coil the spool will be unlatched and the valve will come back to the "Rest" position.

SPECIFICATIONS AND AVAILABLE OPTIONS

MODEL	ORIFICE DIAMETER mm	PRESSURE IN BAR			OPER.	Flow factor k _v (liters/min.')	WEIGHT Kg.	DIMENSION (millimeters)										
		NOMINAL	DIFFERENTIAL					A	B	C	D	E	F	G	H			
			MAX.	MIN.												MAX.		
G 0 3	7 0	C _D																
G 5 3	7 0	C _D																
G 1 3	1 1	E _T																
G 6 3	1 1	E _T																
G 1 3	1 1	F _G																
G 6 3	1 1	F _G																

suffix (options available upon request): ⁽¹⁾ "LT" (low t.amb. certificate), ⁽²⁾ "V" spike suppressor.

a	Body material	b	Port size	c	Seals	d	Protection class
T	Brass.	C	1/4" GAS	D	1/4" NPT	0	Buna N
N	Nickel-plated brass.	E	3/8" GAS	T	3/8" NPT	1	FPM
I	Stainless steel.	F	1/2" GAS	G	1/2" NPT	7	HNBR
						B	Ex-d IIB
						C	Ex-d IIC

Le caratteristiche possono subire variazioni senza preavviso / Characteristics may change without notice.